



■ Features

- AEC-Q200 Compliance
- High precision resistance tolerance: $\pm 0.02\%$
- Low TCR down to $\pm 5\text{ppm}/^\circ\text{C}$
- Advanced sulfur resistance verified according to ASTM B 809
- Gold Termination maximum $0.2\mu\text{m}$ for glueing
- E24-E96 values and non E24-E96

■ Applications

- Automotive
- Telecommunication
- Medical equipment
- Industrial equipment
- Industrial equipmental measurement instrumentation
- industrial machines Various sensors, medical electronics

■ Construction

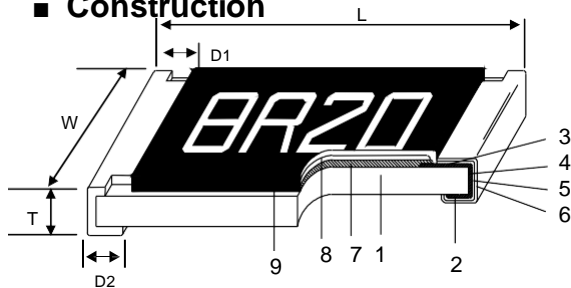

1	Alumina Substrate	4	Edge Electrode	7	Resistor Layer
2	Bottom Electrode	5	Barrier Layer	8	Overcoat
3	Top Electrode	6	External Electrode	9	Marking

■ Dimensions

Unit: mm

Type	Size (Inch)	L	W	T	D1	D2	Weight (g) (1000pcs)
AGM02	0402	1.00 \pm 0.05	0.50 \pm 0.05	0.30 \pm 0.05	0.20 \pm 0.10	0.20 \pm 0.10	0.54
AGM03	0603	1.55 \pm 0.10	0.80 \pm 0.10	0.45 \pm 0.10	0.30 \pm 0.20	0.30 \pm 0.20	1.83
AGM05	0805	2.00 \pm 0.15	1.25 \pm 0.15	0.55 \pm 0.10	0.30 \pm 0.20	0.40 \pm 0.20	4.71
AGM06	1206	3.05 \pm 0.15	1.55 \pm 0.15	0.55 \pm 0.10	0.42 \pm 0.20	0.35 \pm 0.25	9.02

■ Part Numbering

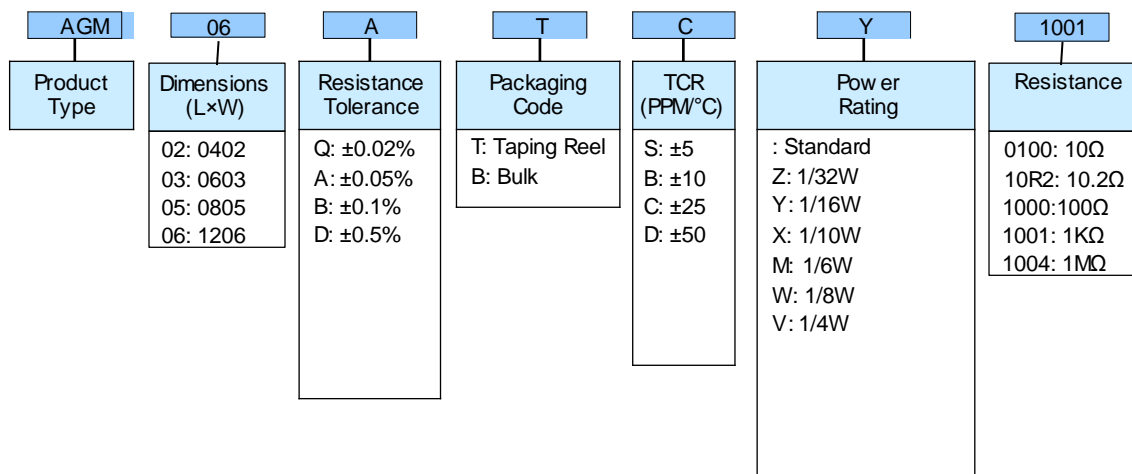



■ Derating Curve

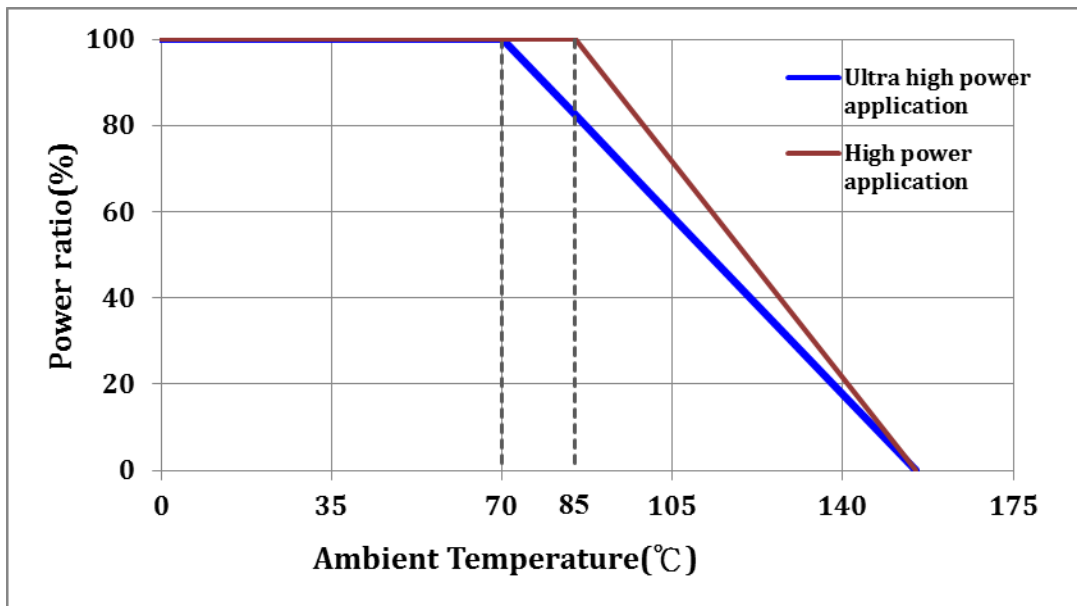

■ Functional Performance

Maximum pulse power limit

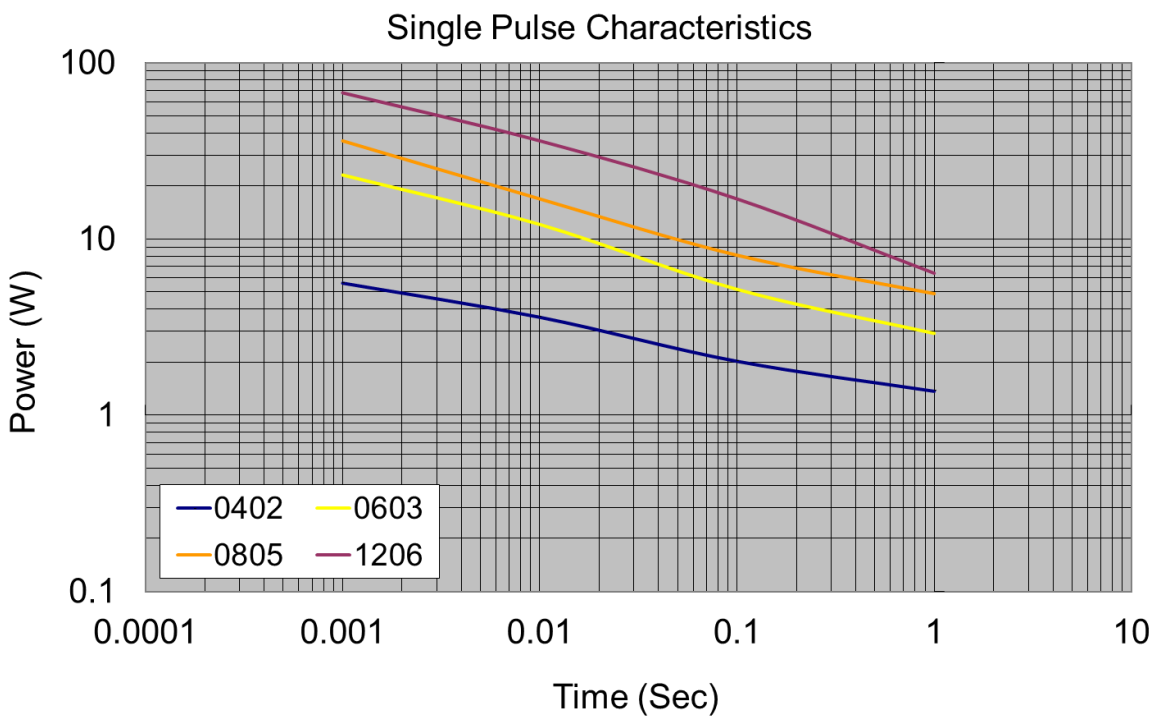



■ Electrical Specifications

Item Type	Power Rating			Max. Operating Voltage	Max. Overload Voltage	Resistance Range				TCR (PPM/°C)
	Standard	High	Ultra high			±0.02%	±0.05%	±0.1%	±0.5%	
AGM02 (0402)	1/32W	1/16W	1/8W	75V	100V	100Ω – 3KΩ				±5
						100Ω – 3KΩ	47Ω – 100KΩ			±10
						100Ω – 3KΩ	47Ω – 100KΩ		47Ω – 150KΩ	±25
						–	–	–	10Ω – 47Ω	±100
AGM03 (0603)	1/16W	1/10W	1/6W	100V	200V	100Ω – 5.1KΩ				±5
						100Ω – 5.1KΩ	47Ω – 270KΩ			±10
						100Ω – 5.1KΩ	47Ω – 270KΩ	47Ω – 332KΩ	47Ω – 1MΩ	±25
						–	–	–	10Ω – 47Ω	±50
AGM05 (0805)	1/10W	1/8W	1/4W	150V	300V	100Ω – 10.2KΩ				±5
						100Ω – 10.2KΩ	47Ω – 475KΩ			±10
						100Ω – 10.2KΩ	47Ω – 475KΩ	47Ω – 2.7MΩ		±25
						–	–	–	10Ω – 47Ω	±50
AGM06 (1206)	1/8W	1/4W	–	200V	400V	100Ω – 33.2KΩ				±5
						100Ω – 33.2KΩ	47Ω – 1MΩ			±10
						100Ω – 33.2KΩ	47Ω – 1MΩ	47Ω – 5.1MΩ		±25
						–	–	–	10Ω – 47Ω	±50

Operating Voltage= $\sqrt{P \cdot R}$ or Max. operating voltage listed above, whichever is lower.

Overload Voltage= $2.5 \cdot \sqrt{P \cdot R}$ or Max. overload voltage listed above, whichever is lower.

Operating Temperature Range=-55 ~ +155°C.



■ Environmental Characteristics

Item	Requirement	Test Method	
Temperature Coefficient of Resistance (T.C.R.)	As Spec.	JIS-C-5201-1 4.8 IEC-60115-1 4.8 -55°C ~ +125°C, 25°C is the reference temperature	
Short Time Overload	$\leq 47 \Omega \Delta R \pm 0.1\%$ $\geq 47 \Omega \Delta R \pm 0.05\%$ for Standard and High power rating	JIS-C-5201-1 4.13 RCWV*2.5 or Max. overload voltage whichever is lower for 5 seconds	
	$\Delta R \pm 0.1\%$ for Ultra high power rating		
Endurance	Standard power rating at 85°C	MIL-STD-202 Method 108 RCWV for 1000 hrs with 1.5 hrs "ON" and 0.5 hrs "OFF"	
	High power rating at 85°C		$\Delta R \pm 0.25\%$
	Ultra high power rating at 70°C		$\Delta R \pm 0.5\%$
Biased Humidity	$\Delta R \pm 0.1\%$ for Standard power rating	MIL-STD-202 Method 103 1000 hrs 85°C/85%RH 10% of operating power.	
	$\Delta R \pm 0.25\%$ for high power rating		
	$\Delta R \pm 0.5\%$ for Ultra high power rating		
High Temperature Exposure	$\leq 47 \Omega \Delta R \pm 0.25\%$ $\geq 47 \Omega \Delta R \pm 0.1\%$ for 0603/0805/1206 size	MIL-STD-202 Method 108 at +155°C for 1000 hrs	
	$\leq 47 \Omega \Delta R \pm 0.25\%$ $\geq 47 \Omega \Delta R \pm 0.2\%$ for 0402 size		
Temperature Cycling	$\leq 47 \Omega \Delta R \pm 0.25\%$ $\geq 47 \Omega \Delta R \pm 0.1\%$	JESD22 Method JA-104 -55°C to +125°C, 1000 cycles	
Resistance to soldering heat	$\Delta R \pm 0.1\%$	JIS-C-5201-1 4.18 IEC-60115-1 4.18 260±5°C for 10 seconds	
Insulation Resistance	>1000 MΩ	JIS-C-5201-1 4.6 IEC-60115-1 4.6 Apply 100V _{DC} for 1 minute	
Bending Strength (Board Flex)	$\Delta R \pm 0.1\%$	JIS-C-5201-1 4.33 Bending once for 60 seconds Bending displacement: 1206 sizes: 3 mm	
Solderability	95% min. coverage	JIS-C-5201-1 4.17 IEC-60115-1 4.17 245±5°C for 3 seconds	
Terminal strength	No broken	AEC-Q200-006 Force of 1.8kg for 60 seconds.	
Mechanical Shock	$\Delta R \pm 0.1\%$	MIL-STD-202 Method 213 Wave Form: Tolerance for half sine shock pulse. Peak value is 100g's. Normal duration (D) is 6.	
Vibration	$\Delta R \pm 0.1\%$	MIL-STD-202 Method 204 5 g's for 20 min., 12 cycles each of 3 orientations, 10-2000 Hz	
ESD	$\Delta R \pm 0.5\%$	AEC-Q200-002 Human body model AGM02、AGM03 0.2KV AGM05、AGM06 1KV	
Resistance to solvents	Marking Unsmearred	MIL-STD-202 Method 215 Add Aqueous wash chemical - OKEM Clean or equivalent. Do not use banned solvents.	



■ Marking

0603 3digit marking

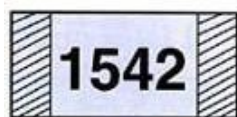

3digit marking for Example: 14C=13K7Ω 13C=13K3Ω

68B=4K99Ω 68X=49.9Ω

Code	E96	Code	E96	Code	E96	Code	E96				
01	100	25	178	49	316	73	562				
02	102	26	182	50	324	74	576				
03	105	27	187	51	332	75	590				
04	107	28	191	52	340	76	604				
05	110	29	196	53	348	77	619				
06	113	30	200	54	357	78	634				
07	115	31	205	55	365	79	649				
08	118	32	210	56	374	80	665				
09	121	33	215	57	383	81	681				
10	124	34	221	58	392	82	698				
11	127	35	226	59	402	83	715				
12	130	36	232	60	412	84	732				
13	133	37	237	61	422	85	750				
14	137	38	243	62	432	86	768				
15	140	39	249	63	442	87	787				
16	143	40	255	64	453	88	806				
17	147	41	261	65	464	89	825				
18	150	42	267	66	475	90	845				
19	154	43	274	67	487	91	866				
20	158	44	280	68	499	92	887				
21	162	45	287	69	511	93	909				
22	165	46	294	70	523	94	931				
23	169	47	301	71	536	95	953				
24	174	48	309	72	549	96	976				
Code	A	B	C	D	E	F	G	H	X	Y	Z
Multiplier	10 ⁰	10 ¹	10 ²	10 ³	10 ⁴	10 ⁵	10 ⁶	10 ⁷	10 ⁻¹	10 ⁻²	10 ⁻³

0603 3digit marking for E24

Example: 101=100Ω 102=1KΩ

E24	10	11	12	13	15	16	18	20	22	24	27	30	33	36	39	43	47	51	56	62	68	75	82	91
-----	----	----	----	----	----	----	----	----	----	----	----	----	----	----	----	----	----	----	----	----	----	----	----	----

0805-2512 4digit marking

Example

Resistance	100Ω	2.2KΩ	10KΩ	49.9KΩ	100KΩ
marking	1000	2201	1002	4992	1003



■ Packaging

Packing Quantity & Reel Specifications

Unit :mm

Type	ØA	ØB	ØC	W	T	Paper Tape (EA)	Emboss Plastic Tape (EA)
AGM02	178.0±1.0	60.0+1.0	13.5±0.7	9.5±1.0	11.5±1.0	10,000	-
AGM03	178.0±1.0	60.0+1.0	13.5±0.7	9.5±1.0	11.5±1.0	5,000	-
AGM05	178.0±1.0	60.0+1.0	13.5±0.7	9.5±1.0	11.5±1.0	5,000	-
AGM06	178.0±1.0	60.0+1.0	13.5±0.7	9.5±1.0	11.5±1.0	5,000	-

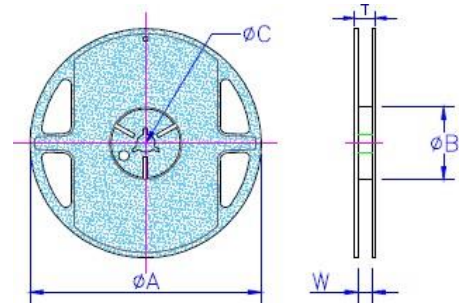

Paper Tape Specifications

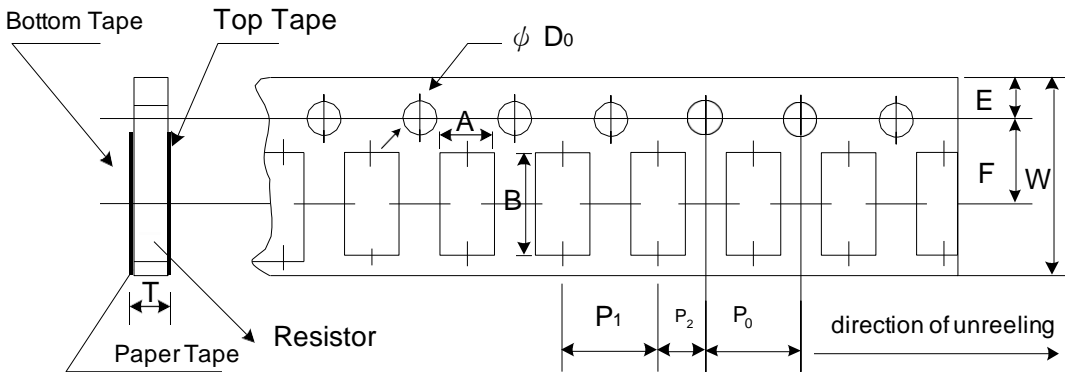

Unit: mm

Type	A	B	W	E	F	P ₀	P ₁	P ₂	ΦD ₀	T
AGM02	0.70±0.05	1.16±0.05	8.00±0.10	1.75±0.05	3.5±0.05	4.00±0.10	2.00±0.05	2.00±0.05	1.55±0.05	0.40±0.03
AGM03	1.10±0.05	1.90±0.05	8.00±0.10	1.75±0.05	3.5±0.05	4.00±0.10	4.00±0.10	2.00±0.05	1.55±0.05	0.60±0.03
AGM05	1.60±0.05	2.37±0.05	8.00±0.10	1.75±0.05	3.5±0.05	4.00±0.10	4.00±0.10	2.00±0.05	1.55±0.05	0.75±0.05
AGM06	2.00±0.05	3.55±0.05	8.00±0.10	1.75±0.05	3.5±0.05	4.00±0.10	4.00±0.10	2.00±0.05	1.55±0.05	0.75±0.05

- Peel force of top cover tape
- The peel speed shall be about 300mm/min±5%
- The peel force of top cover tape shall be between 8gf to 60gf

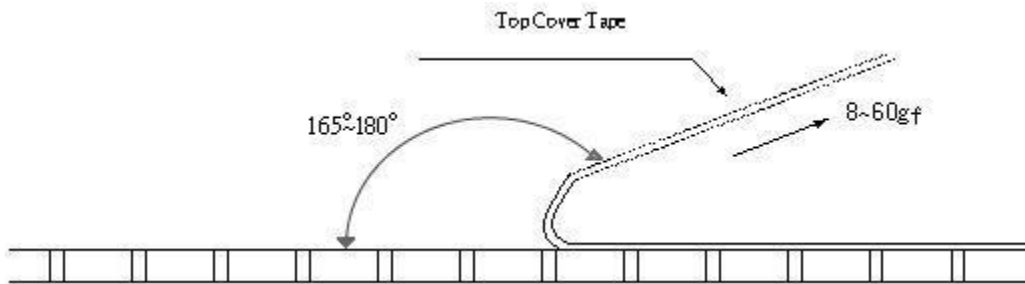



■ Recommend Land Pattern

Unit: mm

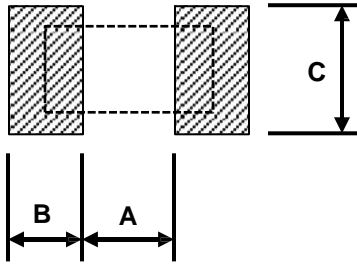

Type	A	B	C
AGM02	0.50	0.50	0.60±0.2
AGM03	1.00	1.00	1.20±0.2
AGM05	1.20	1.40	1.65±0.2
AGM06	2.20	1.40	2.00±0.2

■ Safety Precautions

- Install the following fail-safe design systems to ensure safety. If these products are used in equipment, the defects of these products may cause casualties or other severe damage, such as damage to vehicles (cars, trains, ships), traffic lights, medical equipment, aviation Aerospace equipment, electric heating equipment, combustion/gas equipment, rotating equipment, and disaster/crime prevention equipment.
 - ★ The system is equipped with protection circuits and protection devices.
 - ★ The system is equipped with redundant circuits or other systems to prevent an unsafe state in the event of a single failure.
 - ★ The system is equipped with a system to prevent the spread of fire or prevent malfunctions.